

HAND DRYER

DAHD0047



Dolphy Australia

The sign of quality

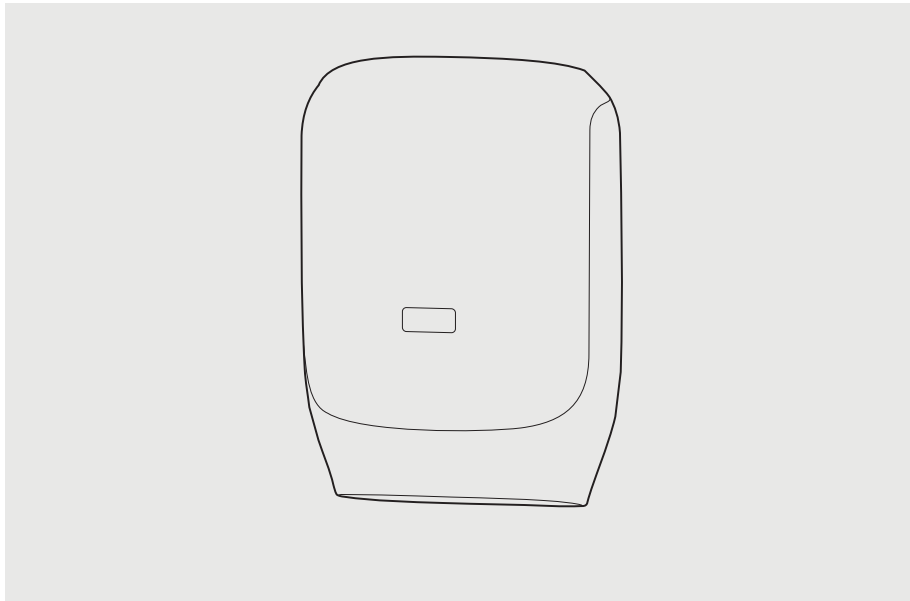

Please read user manual carefully before using

ASSECCORIES LIST





NO.	PICTURE	DESCRIPTION	QTY
①		SCRW,5*35mm	4
②		PLUG, 8*37.5mm	4
③		Hexagon wrench	1
④		User Manual	1

CHART EXPLANATION

Please strictly obey below listed safety signs to avoid any accident in using this product.

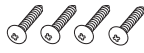
■ Fail to follow these warnings may cause serious injury or death to user



CAUTION This sign means “ it may cause serious injury or death”



NOTICE This sign means “it may cause damage”

■ Safety Caution Signs:



PROHIBITION



COMPULSORY NESS



NOTICE

INSTALLATION NOTICE



Any amendment of this product is prohibited, it may destroy the product or catch a fire.



Installation of this product should be done by a qualified technician.



This appliance is not intended for use by persons (including children) with reduced physical, sensory or mental capabilities, or lack of experience and knowledge, unless they have been given supervision or instruction concerning use of the appliance by a person responsible for their safety.



Keep this product out of flammable items to avoid explosion or fire.



This product is for indoor use only, outdoor installation is not allowed.



Installation of this product must follow the guidance of provided instruction manual.



When install the product, any screw or metal gadget to mount this product should not be contacted with any existing metal on the wall.



Children should be supervised to ensure that they do not play with the appliance.



If the supply cord is damaged, It must be replaced by the manufacture, its service agent or similarly qualified persons in order to avoid a hazard.



Do not use this appliance near bathtubs, showers, basins or other vessels containing water.



Keep this product out of heat, humidity environments, such as shower room or other wet area.

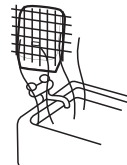

PRODUCT FEATURES

- Adopt the body charge sensing technology
- Automatically stop running after 60secs continuous work
- Environment temperature change, wind type change accordingly
- Changeable HEPA air filter
- Strong power, Energy-efficient

PART DESCRIPTION

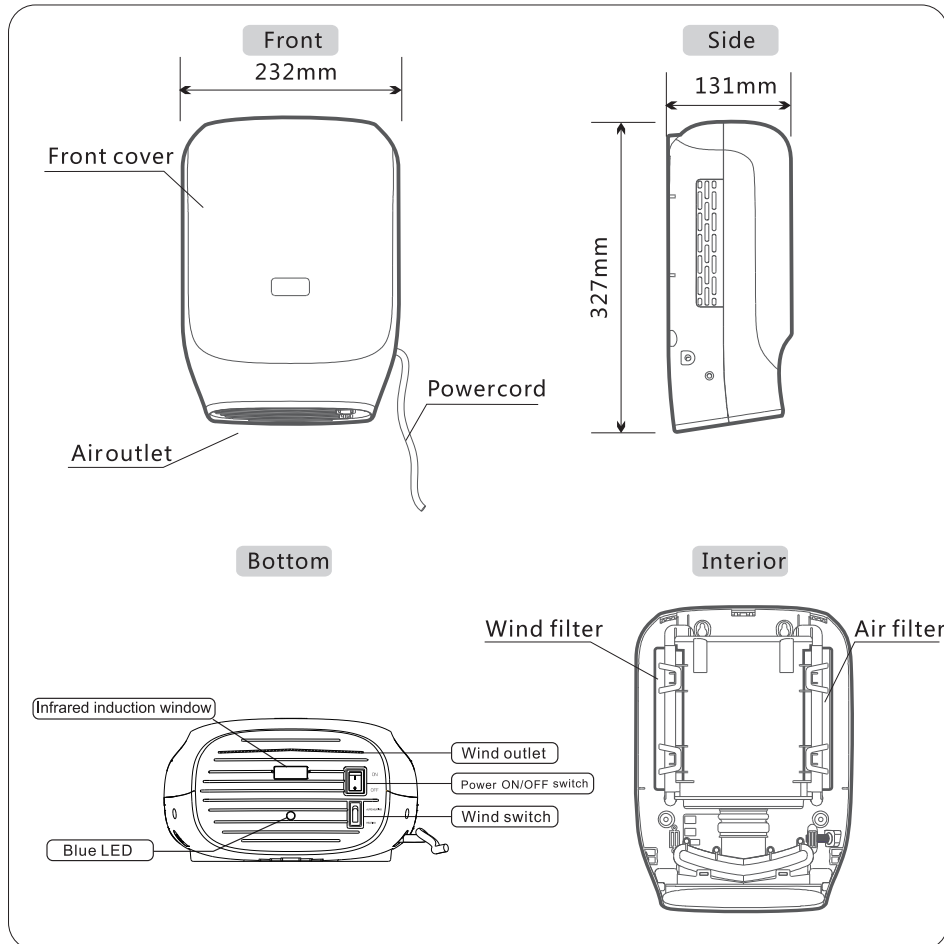

SPECIFICATION

Power	Warm wind: 1450W Cool wind: 650W	Working current	Warm wind 6.6A Cool wind 2.9A
Input Voltage	AC220-240V	Voltage	AC220V
Standby power	≤1.5W	Over heating protection Thermal Fuse protection	95±5°C 142±5°C

INSTALLATION

(1) Ready for installation

Choose a proper place

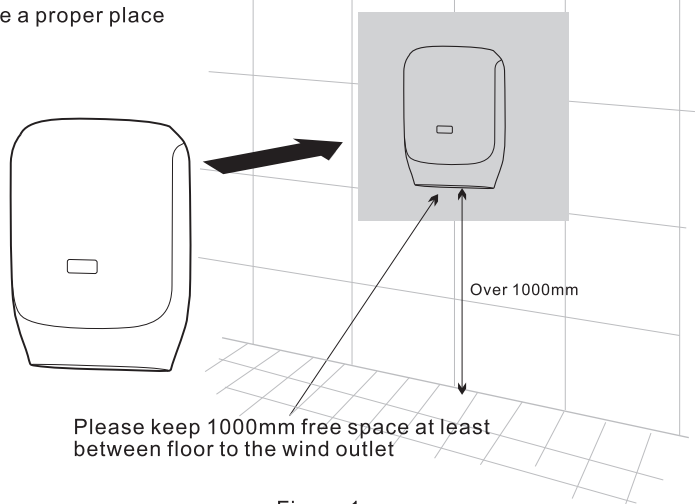

Figure 1

Mounting Height Suggestion

- MAN: Keep 1200mm free space between floor to the wind outlet
- WOMAN: Keep 1150mm free space between floor to the wind outlet

Install this product at a proper height for comfortable use.

- Please keep 1000mm free space at least between floor to the wind outlet

Attention

- Please carefully read the [Instruction for Installation] (Refer to pages 3-4) and follow its instruction. Insure this hand dry have a distance no less than 100mm away from any imflammable items, and keep both sides of this machine clear.
- Please avoid to install this product in a place where the machine become obstructive or the machine is possibly hit by a open door.

INSTALLATION

1

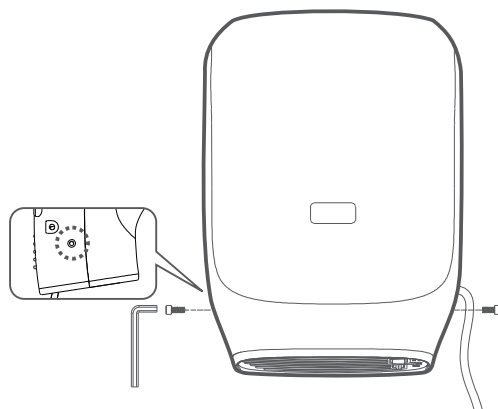

Unscrew the front cover by hexagon wrench

2

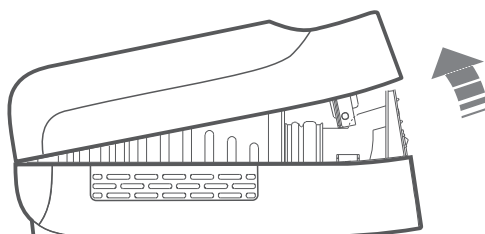

Hold the front cover to open it up

INSTALLATION

3

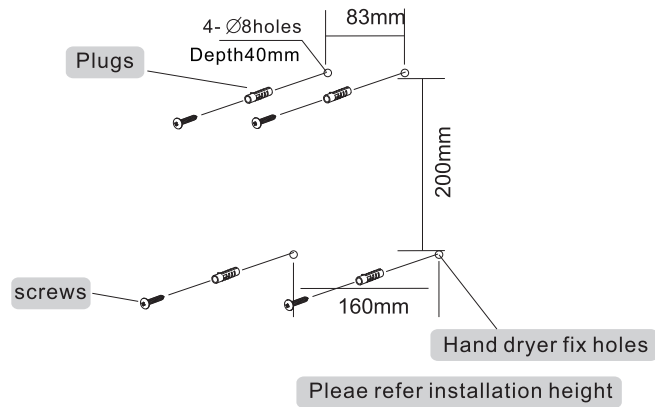

4

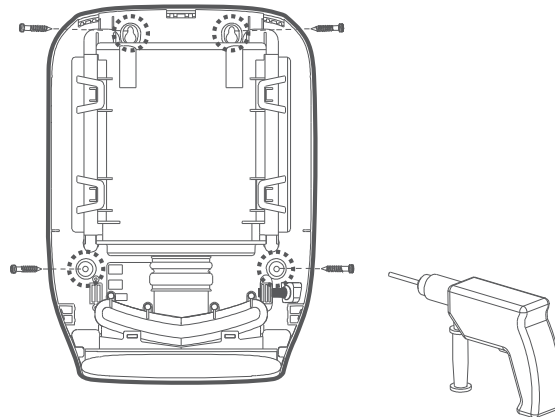

INSTALLATION

5

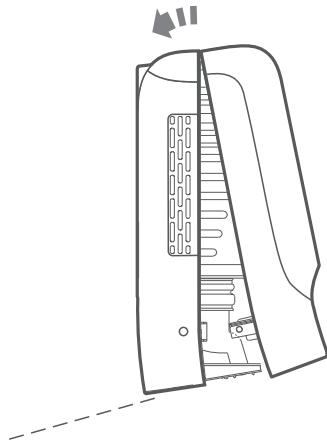

Put the front cover back then close it

6

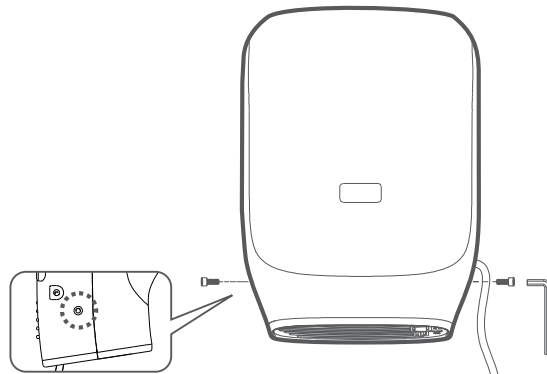

Fix front cover to the base by screws

MAINTENANCE AND AIR FILTER CHANGE

- 1 Turn off the hand dryer then take out the power plug
- 2 Open the front cover (Refer installation to know how to open the front cover)
- 3 There are two air filters are loaded on each side, please take out the air filter box
- 4 Change new air filters then put them back
- 5 Put the front cover back and close it

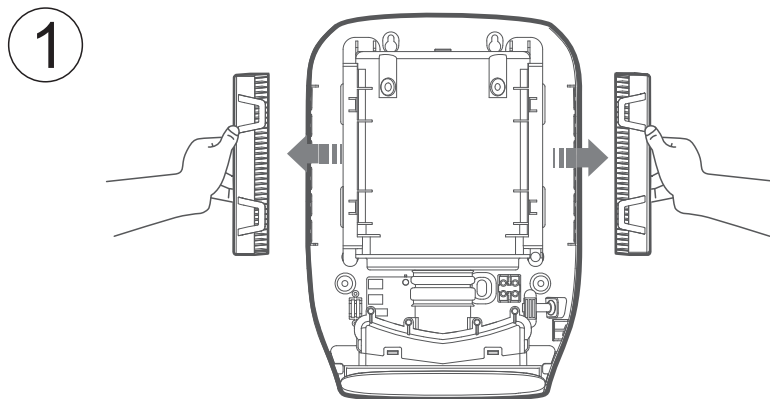

pull the button up to take the air filter box out from the body

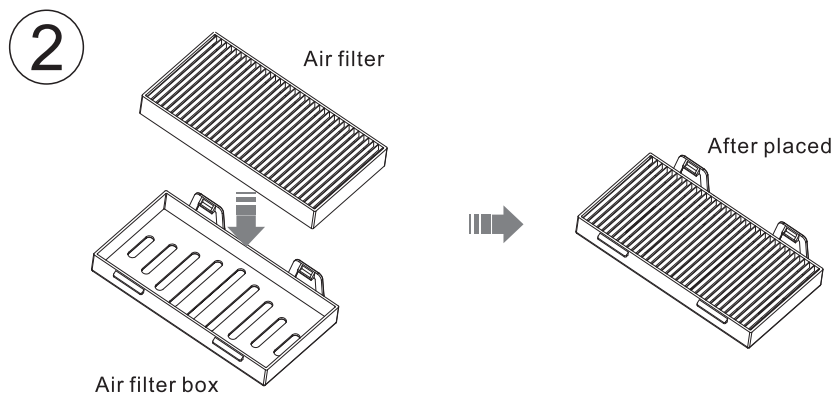

HOW TO USE

Please turn on the power before using

◆ Please check function according to the following:

- 1 Blue LED will light up after power on, temperature controller will adjust the parameters by the environment
- 2 After Blue LED light out, select warm wind
- 3 Place your hands under the sensor area, hand dryer blow warm wind, stop after hands moved away
- 4 Turn wind switch to constant
- 5 Place your hand under the sensor area, hand dryer blow warm wind if the environment temperature is lower than 23 °C, hand dryer blow cool wind if the environment temperature higher than or equal to 23 °C
- 6 All the testing items above are checked, now you can start to use it

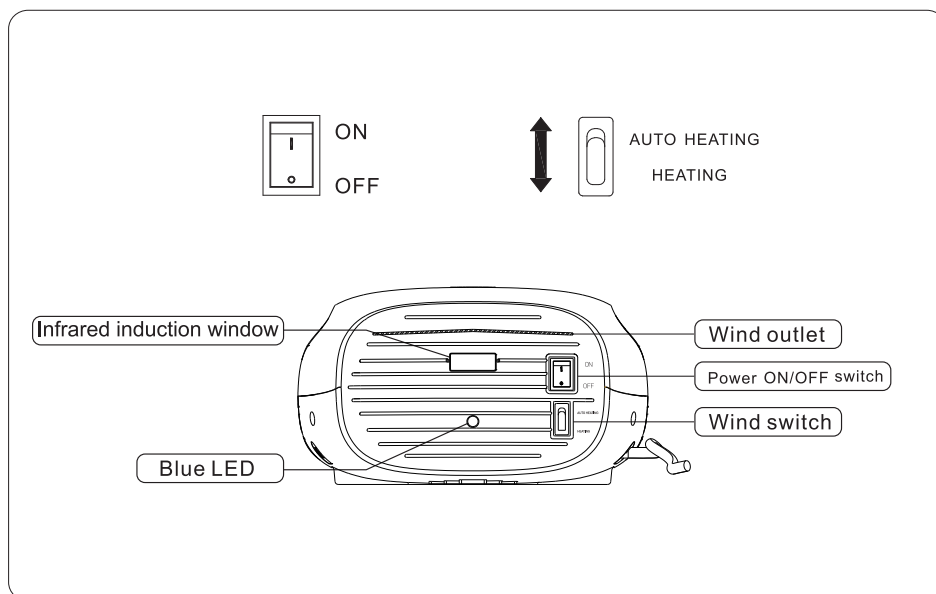

HOW TO USE



- Place your hands under the sensor area
- Rub your palm and move your hand back slowly to dry your fingers
- Machine will stop running after you moved your hands away
- Machine will automatically stop running if use more than 60secs

MAINTAINANCE



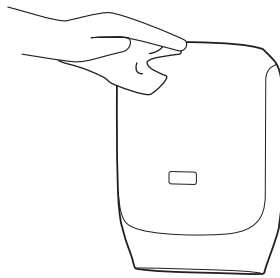







Clean this machine with wet cloth (with slight detergent is recommended),
Always keep the sensor cover clean (Polluted sensor may lose its function)





- Please do not use any chemical diluents, alkalescent detergents, benzene, sterilizing agent or steel brush to clean this machine.

USE ATTENTION

CAUTION

-  Self-disassembly on this hand dryer is prohibited. It may rise electric shock or catch a fire.
-  Unplug the machine before doing any cleaning.
-  To avoid any sparkel occurred by loose plug. Please plug the machine to the socket steadily.
-  Clean up the plug regularly with dry cloth, the plug must be disconnected to the socket while cleaning; Please unplug the machine when it is not in use for a period of time,
-  When pull out the plug, grasp the plug it self rather than hold the cord. Damaged cord may rise electric shock or catch a fire.
-  Prevent the power cord and plug from any damage (Scratch, twist or reassembly the cord is prohibited). Damaged cord or plug may rise electric shock or catch a fire.
-  Cleaning the machine with water is not allowed, it may rise electric shock or catch a fire.
-  Do not use this product when it is surrounded with inflammable items such as paraffin, gasoline or other chemical diluent.
-  Do not plug this machine to the socket with a wet hand.
-  Do not stick the wind outlet with any substances, it may rise electric shock.

NOTICE

-  Do not lean on or pull down the machine anytime to avoid the falling of the machine.
-  Do not cover the wind outlet with hands to avoid injury by the hot wind.



USE ATTENTION



- Should any damaged happened to the power cord, please call the qualified technicians for repairing or return to the manufacturer for repair.
- The wind speed and performance of the hand dryer may vary a little bit subject to the temperature and humidity conditions of the place it works.
- Sometimes the strong wind will blow the water on your wet hands to your face if you place your fingers up along to the hand dryer.
- After continuously working for 60 seconds, this hand dryer will pause automatically due to its built-in self-protection function. If you remove your hand away from it and put back again, it will restart working.
- The standby power consumption is 1.5W when the switch is “ON”